



FEATURE HIGHLIGHTS

- Vehicle/E-Mark ECE R10rev.05

Technology

- 10/100BaseT(X) RJ45
- Broadcast storm protection
- Support IEEE 802.3/ 802.3u/ 802.3x
- 10/100M, Full/Half-Duplex, MDI/MDI-X auto-detection

Reliability

- Redundant dual DC power inputs
- Operating temperature ranges from -10 to +70°C
- Rugged high-strength housing
- DIN-Rail or wall mounting ability

PRODUCT DESCRIPTION

EH2308 has 8 RJ-45 ports, suitable for complex industrial networks. Designed to work in harsh or hazardous industrial environments, it complies with CE, FCC, UL, and RoHS standards. This compact, powerful and cost-effective switch is also available in an E-Mark certified version, allowing in-vehicle uses.

Besides being adaptable to various applications, EH2308 offers improved uptime by two redundant power inputs that can be connected simultaneously to wide-range DC power sources. If one of the power inputs fails, the other live source acts as a backup to automatically provide needed power.

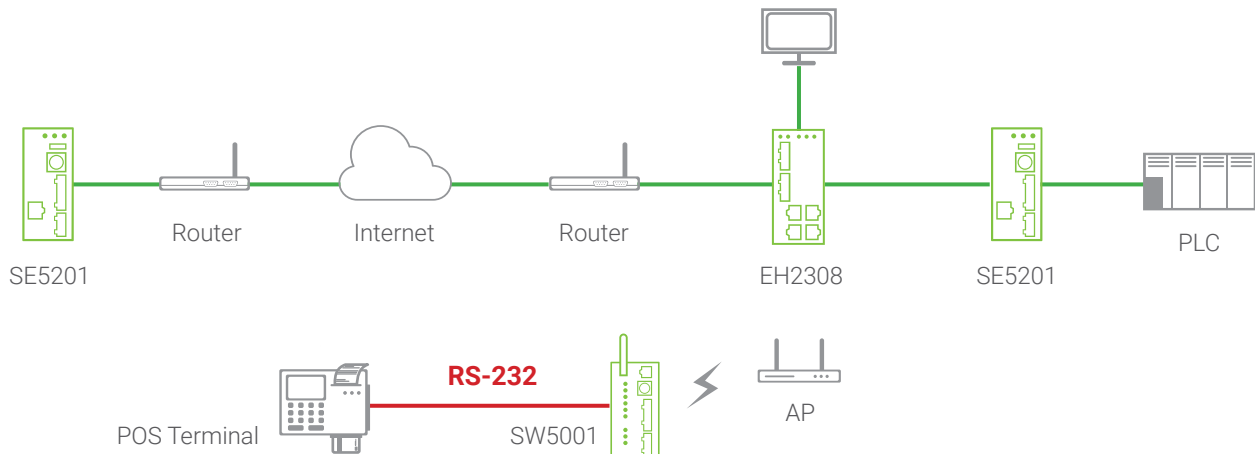

DIMENSIONS & LAYOUT

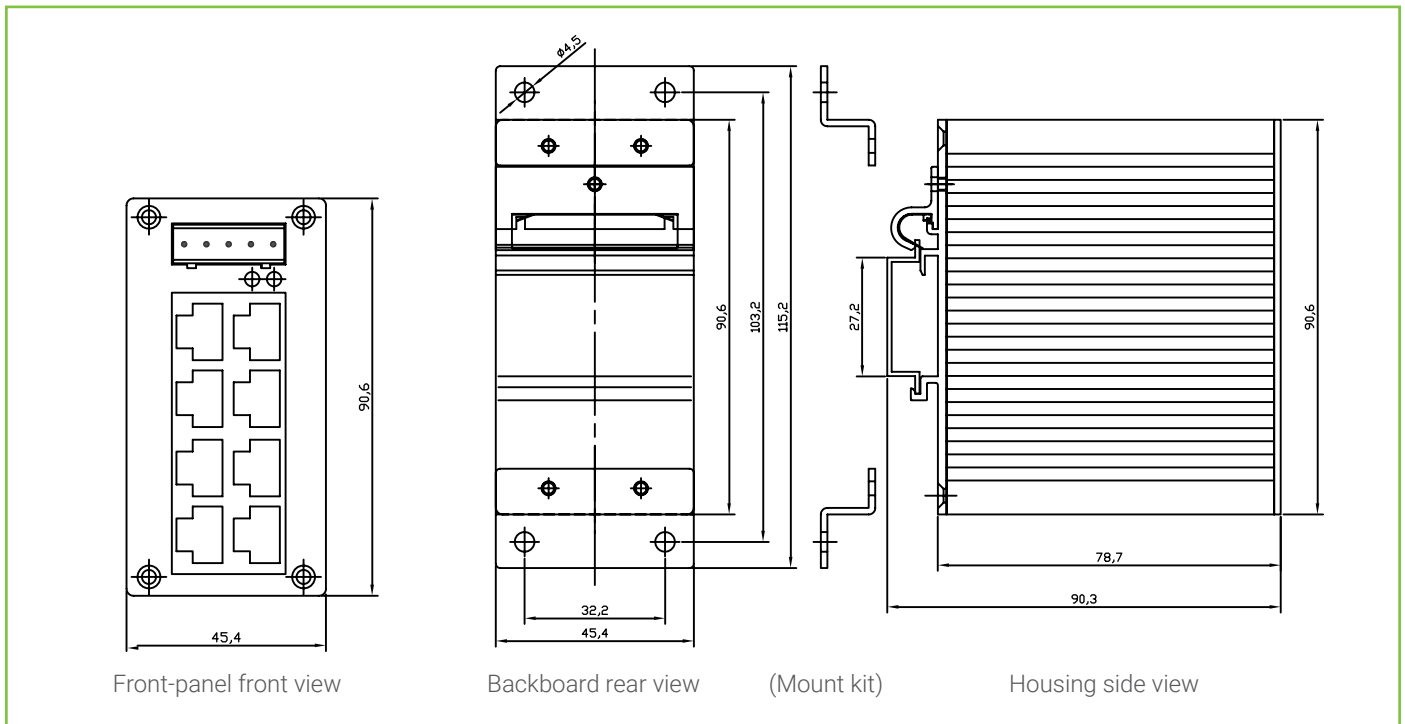

SPECIFICATIONS

Technology	
Standards	IEEE802.3, 802.3u, 802.3x
Processing Type	Store and Forward
Flow Control	IEEE802.3x flow control, backpressure flow control
Interface	
RJ-45 Ports	10/100BaseT(X) auto negotiation speed Full/Half-duplex mode, and auto MDI/MDI-X connection
LED Indicators	Power, 10/100M
Power	
Input	9 to 48 VDC, Dual inputs
Consumption	5 Watts Max
Max current	0.35A @9VDC
Connector	Removable 5-pin Terminal Block for power input
Reverse Polarity Protection	Present
Environment	
Operating	-10°C to +70°C (+14°F to +158°F)
Storage	-40°C to +85°C (-40°F to +185°F)
Ambient Relative Humidity	5%-95% non-condensing
Physical	
Housing	IP30 protection, metal housing
Dimension	45.2mm x 90mm x 78mm (W x H x D)
Weight	255g

REGULATORY APPROVALS

Regulatory Approvals	
UL(Safety)	UL60950-1 2nd Ed. / CSA C22.2 No.60950-1-07 2nd Ed. / CB (IEC62368-1 / IEC62368-1)
FCC(EMI)	FCC Part 15, Subpart B, Class A
CE(EMI)	European Standard EN 55022:2006/A1:2007 Class A EN 61000-3-2:2006 EN 61000-3-3: 1995/A1:2001/A2 :2005
CE(EMS)	EN 55024:1998/A1:2001/A2:2003(IEC 61000-4-2:1995/A2:2000) IEC 61000-4-3:2002 IEC 61000-4-4:2004 IEC 61000-4-5:1995/A1:2000 IEC 61000-4-6:1996/A1:2000 IEC 61000-4-8:1993/A1:2000 IEC 61000-4-11:1994/A1:2000
Test	Item
Vehicle/E-Mark	ECE R10rev.05
Shock	IEC 60068-2-27
Drop	ISTA Test Procedure 2A
Vibration	IEC 60068-2-64
RoHS	Lead(Pb) Free
MTBF	568862 hrs (25°C) / 64.94 years (25°C)
Warranty	5 years

ORDERING INFORMATION

Ordering information

Model Name	Part Number	Description
EH2308	1P1EH230800001G	Industrial 8-port Unmanaged Fast Ethernet Switch with 8x 10/100TX
EH2308 (E-mark)	1P1EH230800003G	Industrial 8-port Unmanaged Fast Ethernet Switch with 8x 10/100TX

Optional Accessories

Model Name	Part Number	Description
UN315-1212 (US-Y)	50500151120003G	Y-Type power adapter, 100-240VAC input, 1.25A @ 12VDC output, US plug, LV6
UNE315-1212 (EU-Y)	50500151120013G	Y-Type power adapter, 100-240VAC input, 1.25A @ 12VDC output, EU plug, LV6