



FEATURE HIGHLIGHTS

Technology

- 10/100BaseT(X) (RJ45)
- Broadcast storm protection
- Support IEEE 802.3/ 802.3u/ 802.3x
- 10/100M, Full/Half-Duplex, MDI/MDI-X auto-detection
- Support 802.1Q/p QoS, prioritizing critical packets such as PROFINET packets

Reliability

- Redundant dual DC power inputs
- Operating temperature ranges from 0~60°C
- Rugged plastic housing
- DIN-Rail or wall mounting ability

PRODUCT DESCRIPTION

EH2008 is an industrial unmanaged Fast-Ethernet switch with 8 RJ-45 ports. It is designed to work in the industrial environment, such as in hazardous locations that comply with CE, FCC, UL, RoHS and REACH standards.

EH2008 protects itself from receiving too many broadcast packets. During normal use, broadcast packets will be forwarded to all ports except the source port. However, it will discard broadcast or multicast packets if the number of those packets exceeds a threshold in a preset period of time. The device also embeds a Packet Prioritization feature that is advanced for unmanaged switches. The switch is able to read the QoS field inside the VLAN tag of the packet, prioritizing those that have to reach the end device first, even during network congestion. This is vital in Industrial Automation applications that are, for example, Profinet Based.

EH2008 provides two redundant power inputs that can be connected simultaneously to wide-range DC power sources. If one of the power inputs fails, the other source acts as a backup to provide power automatically.

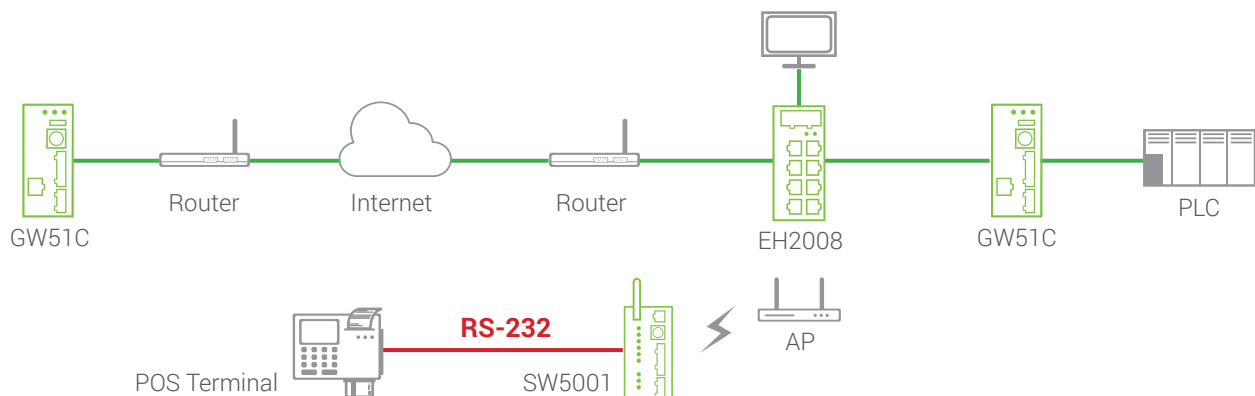

SPECIFICATIONS

Technical Specifications

Model Name	EH2008
Standards	IEEE802.3, 802.3u, 802.3x IEEE802.1Q/p
Processing Type	Store and Forward
Flow Control	IEEE802.3x flow control, backpressure flow control
Interface	
RJ-45 Ports	10/100BaseT(X) auto negotiation speed Full/Half-duplex mode, and auto MDI/MDI-X connection
LED Indicators	Power, 10/100M
Power	
Input	9~48 VDC
Consumption	5.4 W Max
Connector	Removable 5-pin Terminal Block for power input
Reverse Polarity Protection	Present
Environment	
Operating	0°C ~ 60°C (32°F ~ 140°F)
Storage	-20°C ~ 70°C (-4°F ~ 158°F)
Ambient Relative Humidity	5%~95% non-condensing
Physical	
Housing	IP30 protection, plastic housing
Dimension	45.2mm * 90mm * 83mm (W x H x D)
Weight	150g Max

DIMENSIONS & LAYOUT

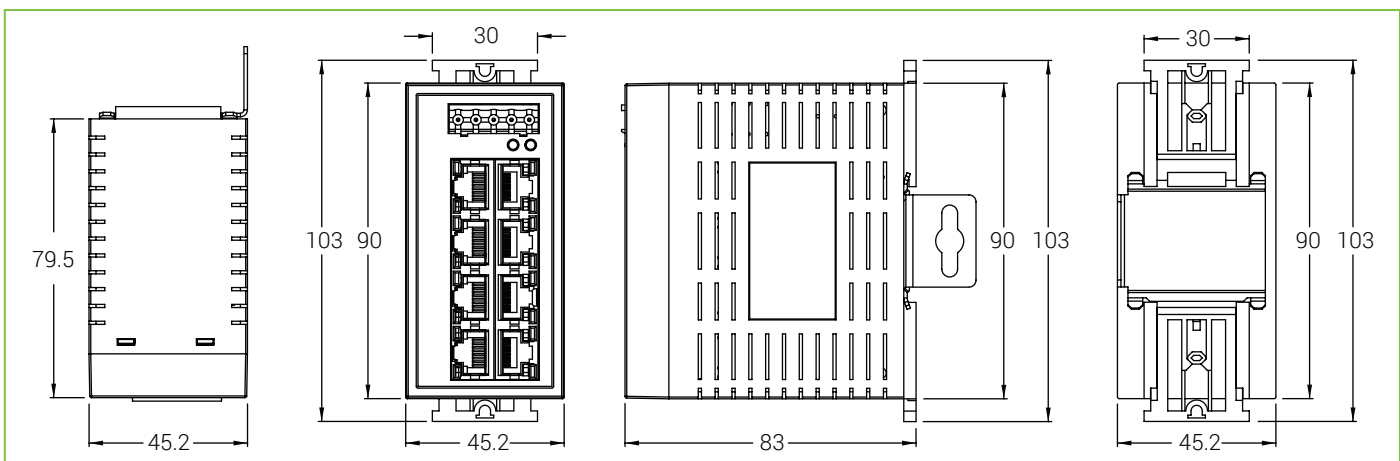

REGULATORY APPROVALS

Approval	
UL(Safety)	UL/IEC 60950-1, UL/IEC 62368-1
FCC(EMI)	FCC 47 CFR Part15, Subpart B, Class A
CE(EMI)	EN55032:2012/AC:2013 Class A EN61000-3-2:2014 EN61000-3-3:2013 EN61000-6-4:2007
CE(EMS)	EN55024:2010/A1:2015 IEC 61000-4-2:2008-12 IEC 61000-4-3:2010-04 IEC 61000-4-4:2012-04 IEC 61000-4-5:2014 IEC 61000-4-6:2013-10 IEC 61000-4-8:2009-09 IEC 61000-4-11:2004-03 EN61000-6-2:2005/AC:2005
RoHS	Lead(Pb) Free
MTBF (according to MIL-HDBK-217F)	443115 hrs(25°C) / 50.58 years(25°C)
Warranty	5 years

ORDERING INFORMATION

Ordering information

Model name	Part Number	Description
EH2008	1P1EH200800001G	Industrial 8-port Unmanaged Fast Ethernet Switch with 8x 10/100TX

Optional Accessories

Model name	Part Number	Description
UN315-1212 (US-Y)	50500151120003G	Y-Type power adapter, 100~240VAC input, 1.25A @ 12VDC output, US plug, LV6
UNE315-1212 (EU-Y)	50500151120013G	Y-Type power adapter, 100~240VAC input, 1.25A @ 12VDC output, EU plug, LV6