



ATOP Technologies, Inc.

Industrial Managed Gigabit PoE Switch

EHG7704/EHG7706/EHG7708/
EHG7708C/EHG7711 Series

Hardware Installation Guide

Version 1.0
Updated in Oct, 2023



Package Check List

Inside the package you will find the following items:

- Industrial Managed Gigabit PoE Switch x1
- 7-Pin 5.08mm Lockable Terminal Block (Already mounted to the device) x 1
- DIN-Rail Kit (Already mounted to the device) x 1
- Protective caps for all SFP and PoE ports (Depend on purchased model)
- Installation Guide with Warranty Card x 1

- Never install or work on electrical or cabling during periods of lightning activity. Never connect or disconnect power when hazardous gases are present.
- Warning: Hot Surface Do Not Touch. RESTRICTED ACCESS AREA: The equipment should only be installed in a Restricted Access Area.
- Caution: CLASS 1 LASER PRODUCT. Do not stare into the laser!
- This equipment should be installed indoor and not connect directly with equipment installed outdoor.

If using optical transceivers to connect to SFP+ or QSFP connectors, only CDRH certified laser class I optical transceivers shall be used.

Product Layout

Front View

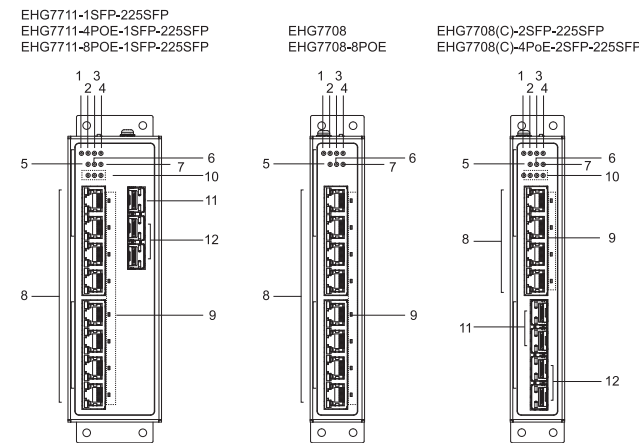

- Ring LED
- Ring Master LED
- RUN LED
- Alarm LED
- PWR1 LED
- PWR2 LED
- Relay out LED
- 8. 10/100/1000 BASE-T(X) RJ-45 Ports and/or 10/100/1000 BASE-T(X) PoE RJ-45 Ports
- 9. PoE LEDs
- 10. SFP Ports LEDs
- 11. 2.5G BASE-X SFP Slots
- 12. 1G BASE-X SFP Slots

Top View

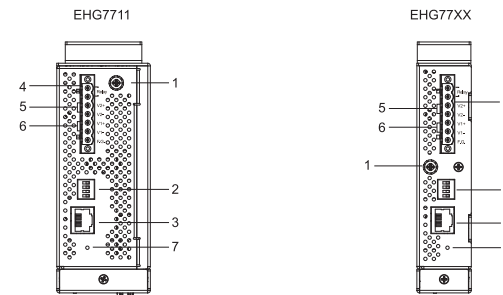

- 1. Grounding Screw
- 2. DIP Switches
- 3. RS-232 Console
- 4. Frame Ground
- 5. Terminal for Power 2
- 6. Terminal for Power 1
- 7. Reset

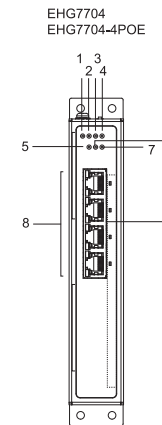
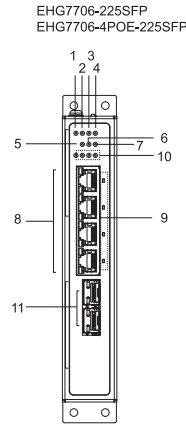

Installation Overview

The device's appearance is as in the figure below.

1. If you have purchased the wall mount kit, proceed to place the screws on the back of the device as show in (Fig. 1).

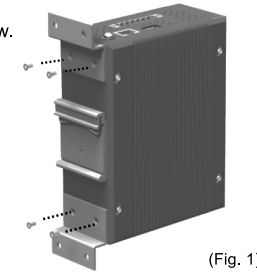

(Fig. 1)

2. Although internal grounding has been done inside, in order to ensure overall maximum performance and protect your device, it is still strongly advised to ground the device properly; hazardous ESD can come into contact and damage your equipment. On the power terminal block, there is a terminal for Frame Ground, you can choose whether to connect it to the grounding or you may opt to connect to the grounding screw next to the terminal block (the one chosen should be connect-ed at all times) (Fig. 2)

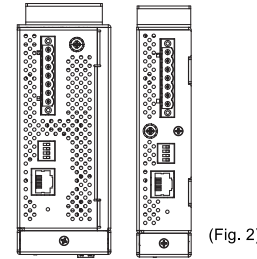

(Fig. 2)

3. Wall mount Screw spec: M3*0.5P
Wall mount Screw Specification:M3;screw depth:6.0mm(Max); screws x 4pcs

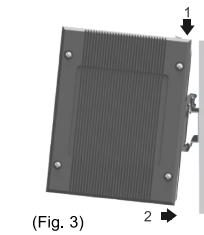

(Fig. 3)

4. You can then choose whether to plug in the other peripheral ports at this point or do it later depending on the actual location of the device or level of comfort for performing such operation.

Remember to plug in the protective caps for the unused SFP and PoE ports.

5. Once the plate has been firmly put in place, proceed to mount the whole device as shown in (Fig. 3). Proceed to (Fig. 4) if you want to remove the device from DIN-Rail.

6. Next we can then proceed to connect the device to the LAN (switch or PC, depending on the case), take care on using the RJ-45 connector; after this we can then proceed to the device's settings

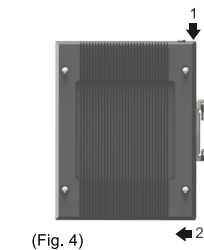

(Fig. 4)

7. Din Rail Screw spec: M4*0.7P
Din Rail Screw Specification:M4; screw depth:6.5mm(Max); screws x 3pcs

- The opening to the sides are for the device's heat dissipation please never obstruct or cover them with any objects or try to insert them through it.
- This switch's factory IP by default is 10.0.50.1 you can access the device by its Web UI once it is connected to a physical network (or using Management Utility, for more information on Management Utility, please refer to its manual). Please be aware that the PC needed for this procedure needs to be in the same subnet, or you may refer yourself to the device User's Manual.

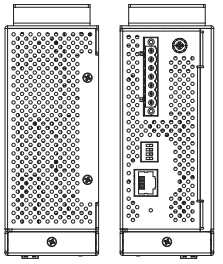

LED Indicators

Name	Color	Status	Message
P1 & P2	Green	On	Power is being supplied through this power input
		Off	Power is not supplied through this power input
ALM	Red	On	Alarm is triggered by user defined events
		Off	Alarm is not triggered
RUN	Green	Blinking	Switch firmware is running normally
		Off	System is not ready or halted
Ring	Green	On	Ring is established and working properly
		Blinking	Ring is enabled
		Off	Ring is disabled
R.M	Green	On	The device is a Master of the ERPS Ring, iA-Ring, or a Head of C-Chain
		Blinking	The device is a Tail of C-Chain
		Off	The device is a Slave of the ERPS Ring, iA-Ring, or a Member of C-Chain
100/1000 SFP	Green	On	1000 SFP
		Off	100 SFP
		Blinking	Data is transmitting on this port
100/1000/2500 SFP	Green	On	2500/1000 SFP
		Off	100 SFP
		Blinking	Data is transmitting on this port
LAN	Amber	On	Ethernet is connected at 1000 Mbps
		Blinking	Ethernet is connected at 100 Mbps
		Off	Ethernet is connected at 10 Mbps
	Green	Blinking	Data is transmitting on this port
		Off	Ethernet is disconnected
		On	Status is on
DI	Green	On	Status is on
		Off	Status is off

Power Requirements

This product is intended to be supplied by a UL listed (Certificate) power supply, output rated is:

- Power input for EHG7708 & EHG7711
9-57VDC , 2.2A Max. (for non-PoE models)
45-57 VDC , 4.5A Max. (for PoE mode)
53-57 VDC, 3.8A Max. (for PoE++ mode)
- Power input for EHG7708C
9-57VDC , 1.2A Max. (for non-PoE models)
45-57 VDC , 2.9A Max. (for PoE mode)
53-57 VDC, 2.5 A Max. (for PoE++ mode)
- Relay Output: 2x Relay Output (24V/1A) with current carrying capacity of 1A @ 24 VDC
- Tma 75 degree C minimum and altitude 2000m, if need further assistance, please contact manufacture or UL File owner or brand owner further information.

The DC supply source for the equipment power supplied shall be an UL certified power source and suitable for specification, rated 9-57 Vdc, 2.2A(for Model EHG7708, EHG7711 Series), 1.2A (for Model EHG7708C Series) minimum, or 45-57Vdc, 4.5A(for Model EHG7708, EHG7711 Series), 2.9A (for Model EHG7708C Series) minimum, or 53-57Vdc, 3.8A (for Model EHG7708, EHG7711 Series), 2.5A (for Model EHG7708C Series)minimum Tma 75 degree C minimum provided by the manufacturer. The power cable connection wire type: copper, clamping torque: 4.5 Lb-In (0.6Nm).

Please use the jacked power cable with 18AWG minimum to connect between the equipment and power source.

- The means of power cord should be connected to a socket-outlet with earthing connection.
- PoE considered a Network Environment 0 per IEC TR62101, and thus the interconnected ITE circuits may be considered SELV. The installation instructions clearly state that the ITE is to be connected only to PoE networks without routing to the outside plant.

Pin Assignments and Connections

2.5G/1G/100/10BASE-T RJ-45 Ethernet, PoE, and RS-232 Console Pinouts

RJ-45								
10/100BASE-T(X)								
Pin	1	2	3	4	5	6	7	8
Signal	TD+	TD-	RD+			RD-		
1000BASE-T								
Pin	1	2	3	4	5	6	7	8
Signal	BI_DA+	BI_DA-	BI_DB+	BI_DC+	BI_DC-	BI_DB-	BI_DD+	BI_DD-
PoE								
Pin	1	2	3	4	5	6	7	8
DC	V+	V+	V-			V-		
RS-232 Console								
Pin	1	2	3	4	5	6	7	8
Signal			Tx	GND	GND	Rx		

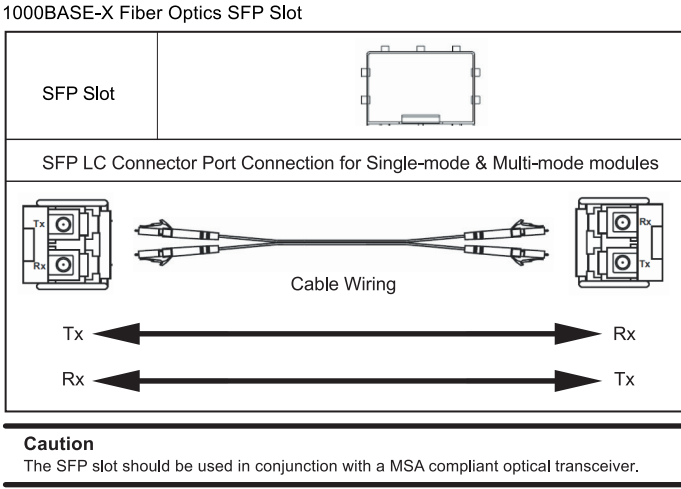

DIP Switch

	DIP Switch		Function	
1	ON		Ring active	
	OFF		Ring inactive	
2	ON		Master	
	OFF		Slave	
3	ON	4	OFF	Compatible Ring
	OFF		ON	iA-Ring
	OFF		OFF	ERPS Ring
5*	Reserve for future use			
6	Reserve for future use			

*Settings are applied when the device is restored to default.

Field Maintenance and Service

If the device requires servicing of any kind, you may need to disconnect and remove it from its mounting. The initial installation should be done in a way that makes this as convenient as possible.

- Voltage/Power lines should be properly insulated as well as other cables. Be careful when handling the so as to not trip over
- Do not under any circumstance insert foreign objects of any kind into the heat dissipation holes located in the different faces of the device. This may not only harm the internal layout but might cause harm to you as well.
- Do not under any circumstance open the device for any reason. Please contact your dealer for any repair needed or follow the instructions on section of your User's Manual.

Mechanical Dimensions (Unit=mm)

Front View

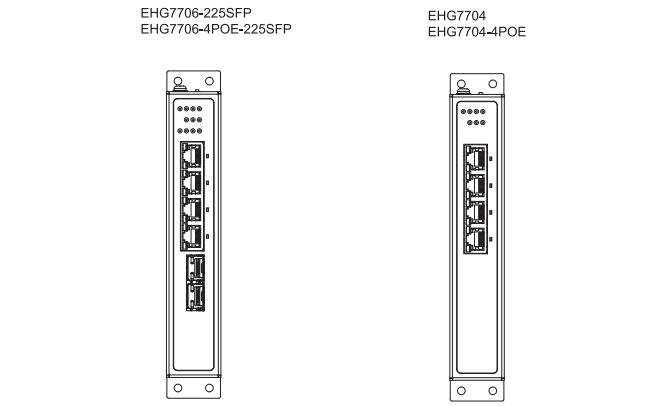
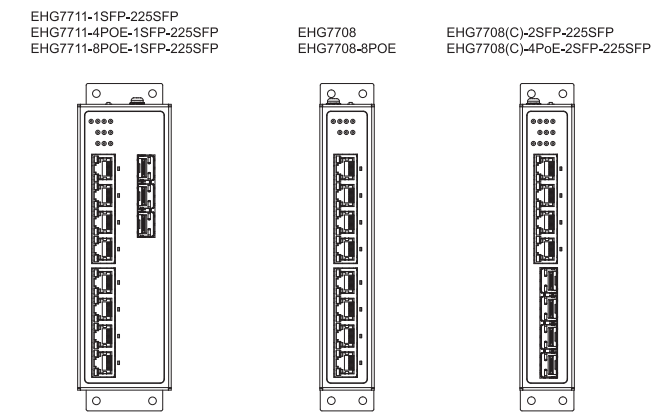

Front & Bottom View

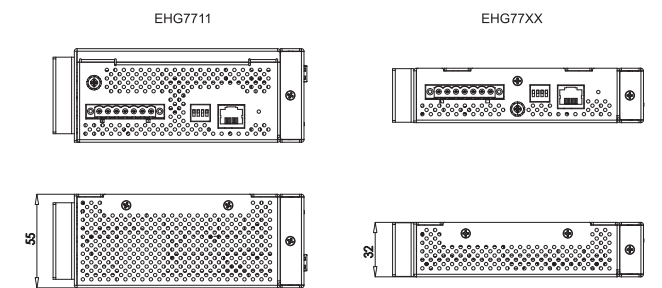

Rear View

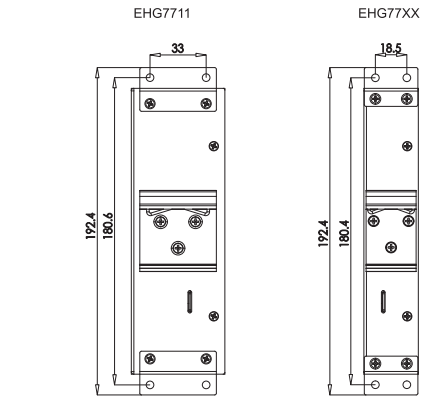

Side View

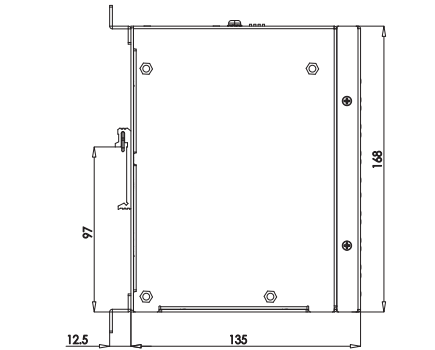

※ The wall mount kit illustrated in this document is for reference only and is not included in the package.

Warranty Policy

Warranty Conditions

Products supplied by Atop Technologies are covered in this warranty for sub-standard performance or defective workmanship. The warranty is not, however, extended to goods damaged in the following circumstances:

- Excessive forces or impacts
- War or an Act of God: wind storm, fire, flood, electric shock, earthquake
- Use of unqualified power supply, connectors, or unauthorized parts/kits
- Replacement with unauthorized parts

RMA and Shipping Costs Reimbursement

Customers shall always obtain an authorized "RMA" number from ATOP before shipping the goods to be repaired to ATOP. When in normal use, a sold product shall be replaced with a new one within 3 months after purchase. The shipping cost from the customer to ATOP will be reimbursed by ATOP.

After 3 months and still within the warranty period, it is up to ATOP whether to replace the unit with a new one; normally, as long as a product is under warranty, all parts and labor are free of charge to the customers.

After the warranty period, the customer shall cover the cost for parts and labor. Three months after purchase, the shipping cost from the customer to ATOP will not be reimbursed, but the shipping cost from ATOP to the customer will be paid by ATOP.

Limited Liability

ATOP shall not be held responsible for any consequential losses from using ATOP's product.

Warranty Period

Product Categories	Warranty	Product Categories	Warranty
Ethernet Switches	5 Years	DIN-Rail Power Supplies	3 Years
Wireless		1 Year	Power Adaptors
Serial Device Servers			Antennas
Modbus Gateways			Other Accessories
Media Converters			
Embedded Device Servers			

The warranty certification will not be effective until an authorized stamp issued by ATOP's overseas agents.

Purchase Date: / / (yyyy/mm/dd)

Serial Number

ATOP Customer Services and Support

- Contact your local dealers or ATOP Technical Support Center at the following number: +886-3-550-8137
- Report any problems via ATOP's website or email
www.atoponline.com ✉ service@atop.com.tw

